

TECHNICAL PRODUCT INFORMATION
LINE MOUNTED REGENERATIVE ASSEMBLIES

Applications

Regenerative circuits are used to provide faster cylinder extension speeds by taking the oil from the rod end and diverting it to the head end of the cylinder. This means that the effective area during extension is only the rod area that gives a faster speed **but also a reduced force**. This means using a cylinder with a 2:1 area ratio between piston and rod, equal speeds and forces can be obtained in both directions without using a double rod.

Sun offers two types of regenerative valve assemblies. One provides full time regeneration and the other is a pressure sensitive regenerative circuit. The full time regeneration has only a limited number of applications and is most commonly used for providing fast extension speeds with low force.

The pressure sensitive regenerative circuit is used in many applications such as compacting machines. The first part of the cylinder extension occurs when there is very little load (for example during initial compaction) and regeneration provides a faster speed. When the load resistance increases, the pressure on the full bore side starts to increase and will pilot open a counterbalance valve connecting the rod side to tank and take the circuit out of regeneration. This then provides a slower speed, as it is now operating on the full bore area, but also a corresponding increase in force. Regenerative circuits **do not** affect the retraction of the cylinder.

It is important to remember to size pipe work correctly to allow for the increased flow going into the full bore side of the cylinder.

The circuit Sun uses for all types of regeneration includes a pilot to close check valve connecting from the rod side to the full bore side. If this circuit is used in applications where the load can extend the cylinder it will be necessary to incorporate a vented load control valve on the rod side to prevent the load running away.

The illustration shows the appropriate calculations for regenerative circuits.

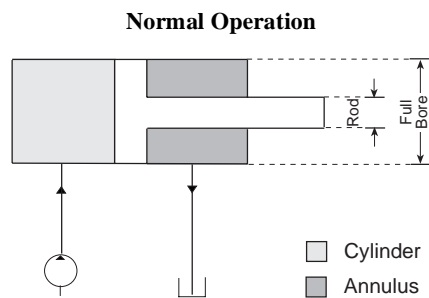

Oil from the pump fills the full bore of a cylinder. With a cylinder ratio of 2:1 and the annulus connected to tank the flow out of the annulus is half of the flow into the full bore.

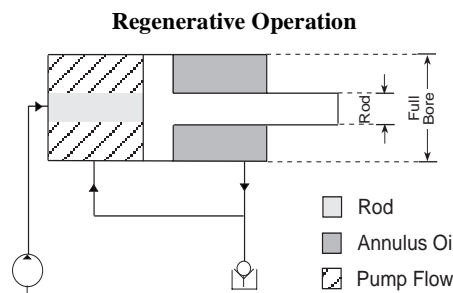

During regen, pump flow into the full bore end fills only the effective area of the rod. The area not filled by the pump flow is made up by the annulus oil feeding back into the full bore. Hence, the reason why during regen, the cylinder extends at a faster rate.

Design Concepts and Features

The first main feature of all Sun regenerative packages is that they are installed after the directional valve controlling the actuator. This means that the higher flows generated are not passed through the directional valve, which can be the same size as for normal circuits. This also means that this package can more easily be added to an existing circuit with the minimum of disruption.

The main feature for the pressure sensitive regenerative circuit is that Sun uses a counterbalance valve to transfer from regeneration to normal operation. This type of valve opens gradually as the pilot pressure increases and gives a much smoother transition compared to the more commonly used sequence valve. It therefore eliminates a great deal of the shock, which can occur during this transition.

The assemblies can be supplied for various flow rates and packages such as line mounted, CETOP sandwich assemblies and gasket-mounted subplates. It is also possible to mount the cartridges directly into the cylinder head.

Standard Assemblies: Line Mounted Regenerative Assemblies

PRESSURE SENSITIVE REGENERATION APPLICATIONS

REGENERATION

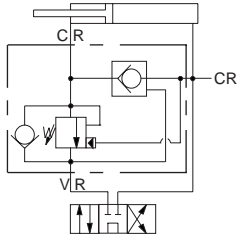

Ports CH,
CR & VR
1/2" BSPP

Assembly
Model Code*
YDCC-LHN-AV

60 L/min. Maximum Regenerative Flow

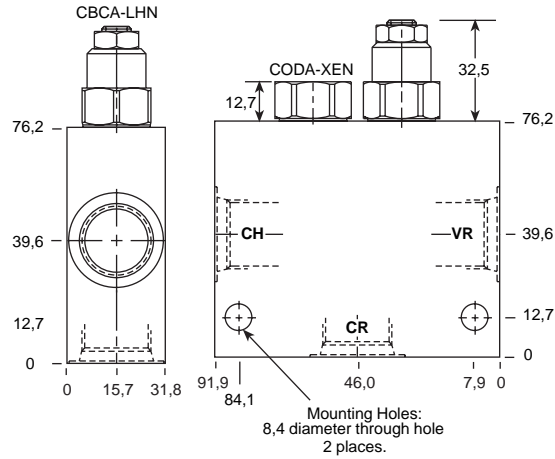

*Add modifier /S to order SG Iron for pressure rating over 210 bar.

Regeneration diminishes progressively above setting of CBCA.

NOTE: Refer to page 223 if load causes cylinder to extend.

*For part number and price for body only contact the Sun factory.

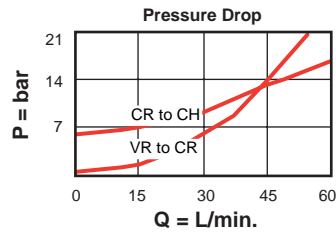

40 L/min. Maximum Regenerative Flow

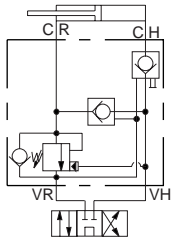

Ports CH,
CR & VR
1/2" BSPP

Assembly
Model Code*
YDCD-LHN-AV

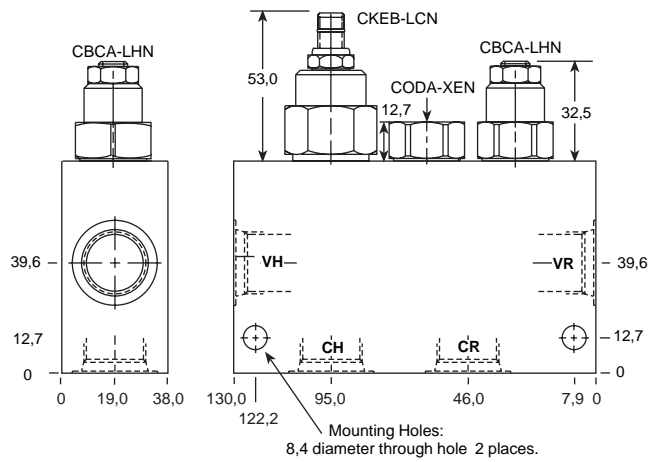

*Add modifier /S to order SG Iron for pressure rating over 210 bar.

Includes CKEB load holding check valve. Regeneration diminishes progressively above setting of CBCA.

NOTE: Refer to page 223 if load causes cylinder to extend.

*For part number and price for body only contact the Sun factory.

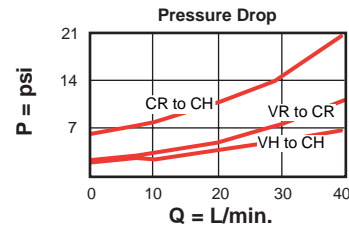

NOTES: Pages 50 for cartridge model CB**_*** and page 78 for CK*B_*** shows performance curves, technical tips, and options. See page vii for technical information about line mount bodies including SAE flange pattern specifications. Consult the Sun Factory for other port sizes available in the bodies shown above. Go to www.sunhydraulics.com for more product information.

PRESSURE SENSITIVE REGENERATION APPLICATIONS

REGENERATION

120 L/min. Maximum Regenerative Flow

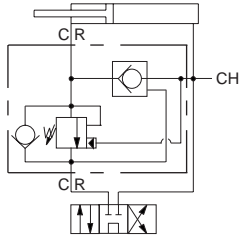

Ports CH, CR & VR	Assembly Model Code*
3/4" BSPP	YDEC-LHN-AW

*Add modifier /S to order SG Iron for pressure rating over 210 bar.

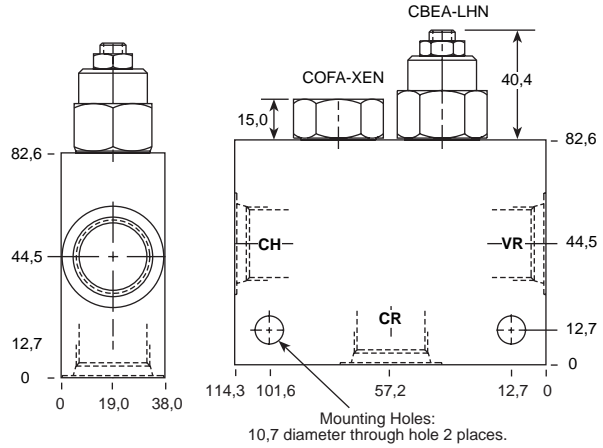

Regeneration diminishes progressively above setting of CBEA.
NOTE: Refer to page 223 if load causes cylinder to extend.
 *For part number and price for body only contact the Sun factory.

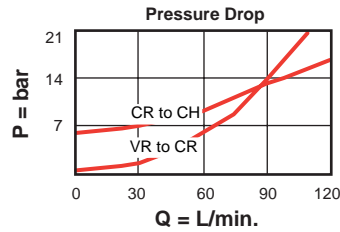

80 L/min. Maximum Total Flow with Load Holding Check Valve

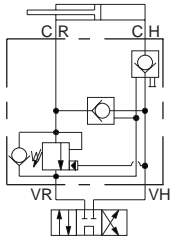

Ports CH, CR & VR	Assembly Model Code*
3/4" BSPP	YDED-LHN-AW

*Add modifier /S to order SG Iron for pressure rating over 210 bar.

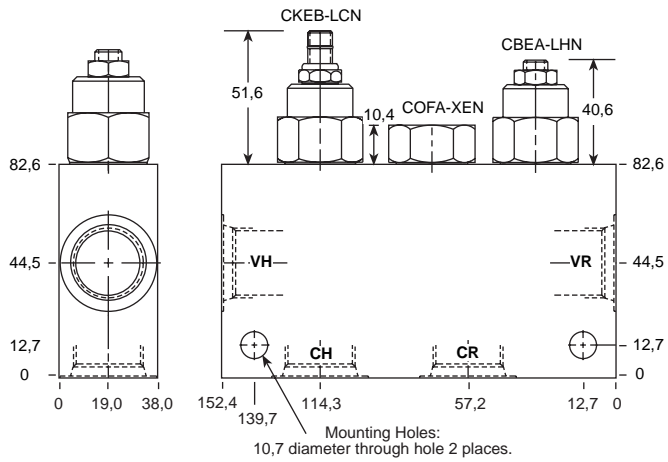

Regeneration diminishes progressively above setting of CBEA.
NOTE: Refer to page 223 if load causes cylinder to extend.
 *For part number and price for body only contact the Sun factory.

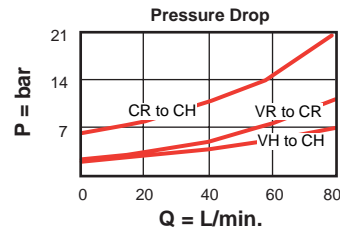

NOTES: Pages 50 for cartridge model CB**.* and page 78 for CK*B-*** shows performance curves, technical tips, and options. See page vii for technical information about line mount bodies including SAE flange pattern specifications. Consult the Sun Factory for other port sizes available in the bodies shown above. Go to www.sunhydraulics.com for more product information.

Standard Assemblies: Line Mounted Regenerative Assemblies

PRESSURE SENSITIVE REGENERATION APPLICATIONS

REGENERATION

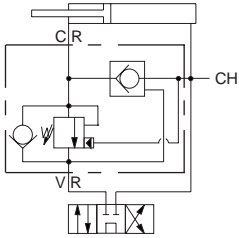

Ports CH, CR & VR	Assembly Model Code*
3/4" BSPP	YDGC-LHN-AW
1" BSPP	YDGC-LHN-AX
1 1/4" BSPP	YDGC-LHN-AY
1" SAE C61	YDGC-LHN-AP/M

*Add modifier /S or /T to order SG Iron for pressure rating over 210 bar.

240 L/min. Maximum Regenerative Flow

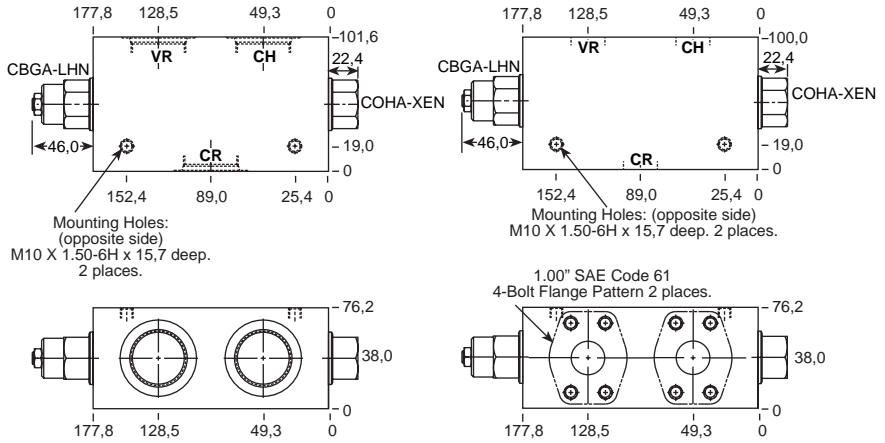

Regeneration diminishes progressively above setting of CBGA.
NOTE: Refer to page 223 if load causes cylinder to extend.
 *For part number and price for body only contact the Sun factory.

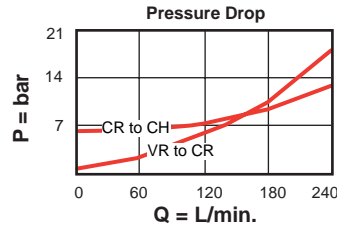

200 L/min. Maximum Regenerative Flow

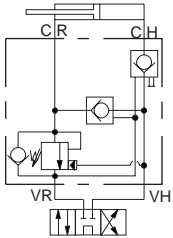

Ports CH, CR & VR	Assembly Model Code*
3/4" BSPP	YDGD-LHN-AW
1" BSPP	YDGD-LHN-AX
1 1/4" BSPP	YDGD-LHN-AY
1 1/4" SAE C61	YDGD-LHN-AQ/M

*Add modifier /S or /T to order SG Iron for pressure rating over 210 bar.

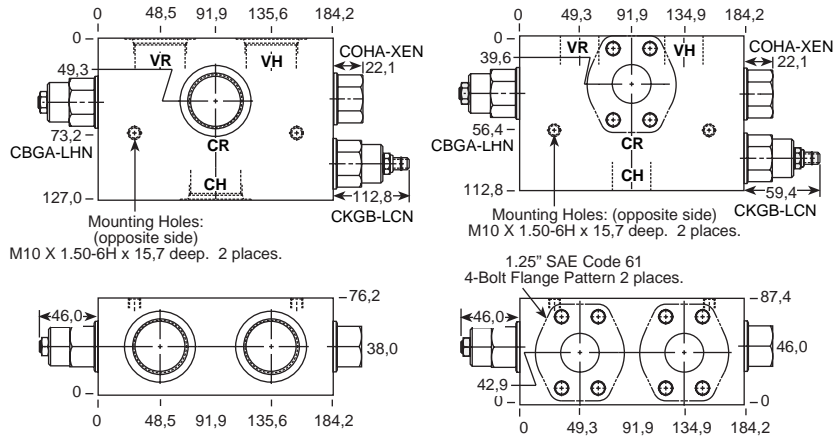

Regeneration diminishes progressively above setting of CBGA.
NOTE: Refer to page 223 if load causes cylinder to extend.
 *For part number and price for body only contact the Sun factory.

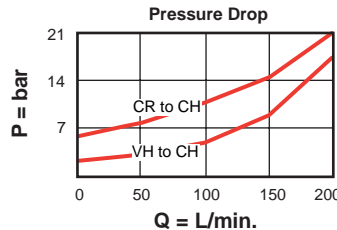

NOTES: Pages 50 for cartridge model CB**-* and page 78 for CK*B-* shows performance curves, technical tips, and options. See page vii for technical information about line mount bodies including SAE flange pattern specifications. Consult the Sun Factory for other port sizes available in the bodies shown above. Go to www.sunhydraulics.com for more product information.

PRESSURE SENSITIVE REGENERATION APPLICATIONS

REGENERATION

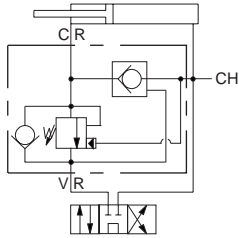

Ports CH, CR & VR	Assembly Model Code*
1" BSPP	YDJC-LHN-AX

480 L/min. Maximum Regenerative Flow

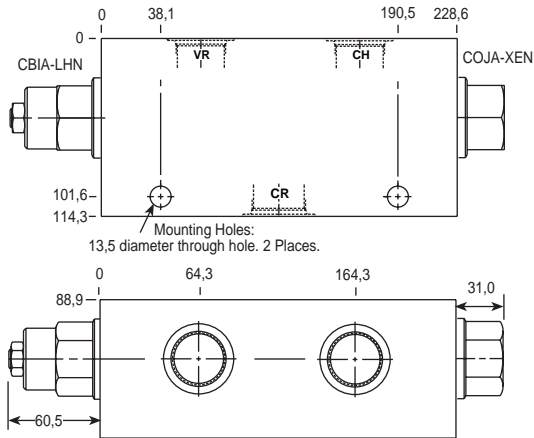

*Add modifier /S to order SG Iron for pressure rating over 210 bar.

Regeneration diminishes progressively above setting of CBIA.
 NOTE: Refer to page 223 if load causes cylinder to extend.
 *For part number and price for body only contact the Sun factory.

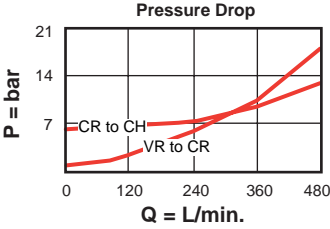

960 L/min. Maximum Regenerative Flow

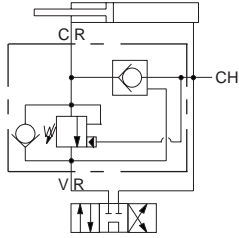

Ports CH, CR, VR	Assembly Model Code*
2" SAE C61	YDJC-LHN-AS/M

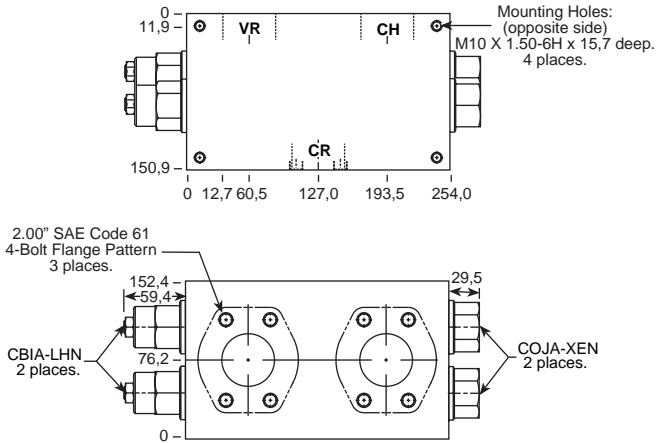

*Add modifier /T to order SG Iron for pressure rating over 210 bar.

Regeneration diminishes progressively above setting of CBIA.
 NOTE: Refer to page 223 if load causes cylinder to extend.
 *For part number and price for body only contact the Sun factory.

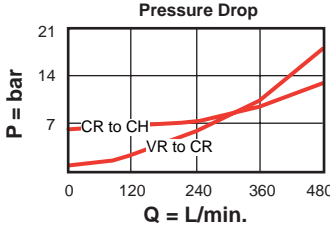

NOTES: Pages 50 for cartridge model CB**-* and page 78 for CK*B-* shows performance curves, technical tips, and options. See page vii for technical information about line mount bodies including SAE flange pattern specifications. Consult the Sun Factory for other port sizes available in the bodies shown above. Go to www.sunhydraulics.com for more product information.

